

User's Guide

Instructions for Installation and Operation



900 MHz Spread Spectrum
Remote Receiver
Models:
SF900C4-B-RX
SF900C8-B-RX
SF900C10-B-RX

900 MHz Spread Spectrum
Remote Control
Model SFT900Cn-B
n=1 to 10



900 MHz Spread Spectrum
Remote Receiver- Outdoor
Models:
SF900C4-B-RX-OPT14
SF900C8-B-RX-OPT14
SF900C10-B-RX-OPT14

900 MHz Spread Spectrum
Remote Control
Model SFT900Cn-B-NTX
n=1 to 3



Models: SF900C and SFT900C

FCC ID: QY4-618

"This device complies with Part 15 of the FCC Rules. Operation is subject to the following two conditions: (1) this device may not cause harmful interference, and (2) this device must accept any interference received, including interference that may cause undesired operation."

INSTRUCTION TO THE USER

Note: This equipment has been tested and found to comply with the limits for a Class B digital device, pursuant to part 15 of the FCC Rules. These limits are designed to provide reasonable protection against harmful interference in a residential installation. This equipment generates, uses and can radiate radio frequency energy and, if not installed and used in accordance with the instructions, may cause harmful interference to radio communications. However, there is no guarantee that interference will not occur in a particular installation. If this equipment does cause harmful interference to radio or television reception, which can be determined by turning the equipment off and on, the user is encouraged to try to correct the interference by one or more of the following measures:

- Connect the equipment into an outlet on a circuit different from that to which the receiver is connected.
- Consult an experienced radio/TV technician for help.

Changes or modifications not expressly approved by *Applied Wireless* could void the user's authority to operate the equipment.

Applied Wireless Inc.

Multi-channel Long Range Remote Control

Model SFT900C(1 to 4) Transmitter with SF900C4-B-RX Receiver
or SFT900C(1 to 8) Transmitter with SF900C8-B-RX Receiver
or SFT900C10 with SF900C10-B-RX Receiver

Product Descriptions

The SF900C Series receivers and SFT900 series handheld or wall mount remotes operate as a 4, 8 or 10 channel wireless relay system. When a button is pushed on the SFT900C transmitter, an RX LED and audible tone will indicate that the proper relay was triggered after receiving a verified acknowledgment reply from the SF900C receiver.

Multiple transmitters can be used with one receiver as well as one transmitter can transmit to multiple receivers.

Default button mode is momentary. Latched, toggle and mixed modes of operation are also available.

These products utilize frequency hopping spread spectrum technology and are resistant to interference and multipath fading. All outputs are dry contacts and independently isolated from each other and from the power supply and ground. The antenna, however, is connected to the internal ground and, if AC powered, the antenna must be isolated from the power input ground.

Expected range with these products is ½ to 2+ miles*. The receiver requires 12 to 24 Volts AC or DC (supply not included). 120/240VAC option is also available on the-OPT14 outdoor receivers.

Features

- Works with SFT900 Series handheld and Wall Mount Transmitters
- Can work with Multiple SFT900C Transmitters
- 4-Inputs/4 each-10A Relay Outputs or
- 8-Inputs/8 each 10A Relay Outputs or
- 10 each 10A Relay Outputs
- Long Range: 1/2 to 2.5-miles
- Sends "Acknowledgement" Back to Transmitter Upon Receiving a Command
- Spread Spectrum Technology
- 12-24 Volt DC or AC Operation
- NEMA 4X Enclosure Option
- 120/240 VAC Power Input Option
- Antenna Included
- FCC Certified
- Made in USA

Typical Applications

- Pump Control
- Motor Control
- Solenoid Control
- Lighting Control
- Access Control
- Conveyer Control

LED Indicators (Receiver)

Power LED: Indicates that voltage is applied to the receiver.

Learn LED: LED blinks when in the learn mode.

Relay LED's : They indicate for each relay whether the relay is activated.

Data LED: LED indicates reception of RF signal at the receivers frequency of operation. For troubleshooting purposes, it can indicate the following:

- 1) Whether the transmitter is actually transmitting.
- 2) Whether there are interfering signals at the receiver's frequency of operation. The LED should be dim if the transmitter has no input activated or button is not being pressed. Any LED indication would indicate that an interfering signal is present, the severity of which is indicated by how much the LED is activated.

* Unobstructed, straight line-of-sight range. For non-line-of-sight applications, range will be somewhat less depending on the nature of the obstruction(s).

Installation Instructions

BEFORE BEGINNING THE INSTALLATION

Plan your installation carefully. The physical location and orientation of the unit will have an influence on reception, particularly at longest ranges. For best results, **the antennas should be positioned vertically (pointing either up or down)**. If necessary, use double-sided foam tape or hook & loop fasteners (not supplied) to secure the unit to a non-metallic *vertical* surface. Also, keep in mind that the RF signal from these spread spectrum products will travel through most non-metallic building materials (wood, stucco, brick, etc.), however maximum stated reception range is based on unobstructed line of sight conditions. Antenna extension cables are available when necessary to optimize antenna placement for range considerations.

POWER HOOKUP

The SF900C-RX receiver has an internal DC/DC converter, so it may be connected to either 12-24 VDC or 12-24 VAC. The rightmost upper and lower terminals are for power. When using DC, the polarity is not important.

The SF900C-B-RX-OPT14 outdoor models are also available with optional 124/240VAC internal power supply.

MULTIPLE RECEIVERS TO ONE TRANSMITTER HOOKUP

If multiple receivers are used in a system, ACKNOWLEDGMENT must be disabled in all but one receiver. If this is not done, the transmitter will have multiple transmissions coming back at it at the same time, essentially jamming it. This is an internal jumper setting that the installer can do, or the factory can do. In the multiple receiver system, all receivers must be ordered from the factory with the same address code. This code can be found on the label when ordering additional receivers for the same system.

MULTIPLE TRANSMITTERS TO ONE OR MORE RECEIVERS

Multiple transmitters to one or more receivers will not work with the standard product. Applied Wireless has developed special "polling" firmware for such applications. Model number is SF900C4-B-B-ODT. Call factory for details.

LEARN PROCEDURE

To pair a SF900C-B-RX to be used as a receiver with a SFT900C handheld transmitter, the case of the SFT900C will have to be removed to access the learn button. Remove the 4 screws from the back cover and remove it. Place both units in the learn mode by pushing their respective learn buttons. The learn lights will flash. Then press the learn button on the SFT900C handheld transmitter again and the pairing will take place. Replace the cover. The SFT900C Remote unit will have learned and adopted the code and frequency of the SF900C Base unit. Other transmitters can be added one at a time by using the SF900C as the base unit by repeating the learn process. All of the transmitter will have learned and adopted the SF900C Base unit's code and frequency.

More SF900C receivers can be added to the above system one at a time by using the same SF900C as the Base unit. However, the covers will have to be removed from the additional SF900C receivers and the ACK jumper will have to be moved to the NO ACK position to disable acknowledgements. When a signal is received from a transmitter, only one receiver, logically the Base unit, must reply with an acknowledgment to avoid collisions.

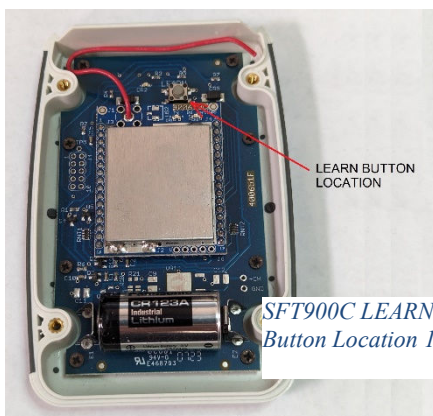
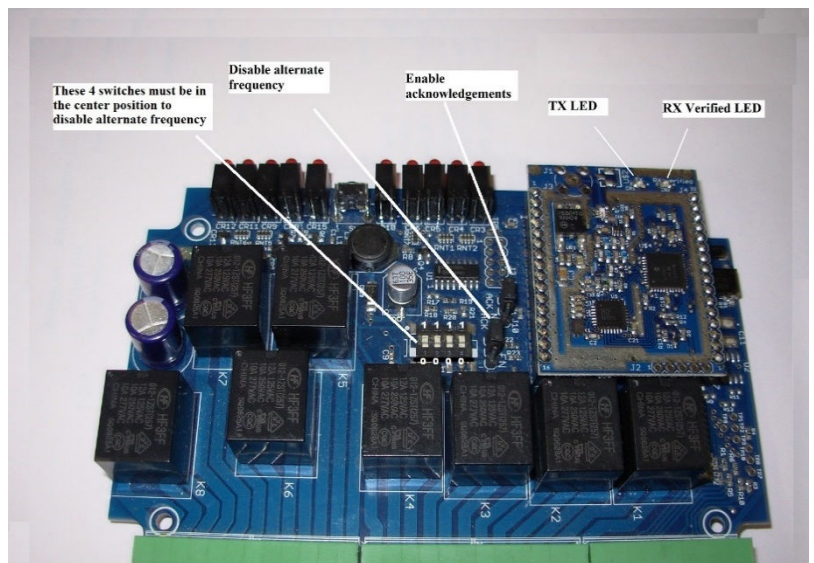

CHANGING THE FREQUENCY

It is rarely necessary to manually change the frequency, however the following outlines the procedure should it be necessary:

From the factory, the units are set to 1 of 32 frequencies. If two or more Base units are to be operating in the same area and they happen to have the same frequency, the Base units can be set to different frequencies if they aren't already. There are 16 possibilities for manually set frequencies.

Using the 4-position dip switch S1 and an enable jumper J4, 16 possible Manual Set frequencies are possible. To enable the alternate frequency selection, Jumper J4 must be moved to the two pins closest to the "EN" position and each of the S1 dip switches must be moved up or down.

To *disable* the alternate frequency selection, the enable jumper must be moved to the two pins farthest from the EN location and the dip switches must be moved to the center tri-state position. See the Frequency Select Switch Table. (1 is UP and 0 is DOWN.)

In the photo above, the frequency code is "70" (last 2 of the address code). In the frequency table, it can be seen that that corresponds to a frequency of 915.00 MHz.

NOTE: Whenever the frequency select switch, S1, is changed on the Base unit, the power has to be turned Off and back On again for the frequency change to take effect. Then, the Learn Procedure will have to be repeated for all of the Remote units associated with the Base unit that has a new frequency setting.

SF/SFA900 FREQUENCY TABLE								
(Address Code is Found on Label)								
			Serial ID		Frequency			
Frequency		Frequency	Address Code Position, Left to Right				MANUAL (ALTERNATE) SETTINGS	
CHANNEL	FREQUENCY	CHANNEL	1	2	3	4	4-Pos Switch (S1)	J4 Jumper
Decimal	MHz	HEX	<<<<<< 4-Digit Hex Address Code >>>>>>				BINARY, lsb first	Setting
0	903.00	00	x	x	0,2,4,6,8,A,C or E	0	0000	EN
1	903.75	01	x	x	0,2,4,6,8,A,C or E	1		
2	904.50	02	x	x	0,2,4,6,8,A,C or E	2	1000	EN
3	905.25	03	x	x	0,2,4,6,8,A,C or E	3		
4	906.00	04	x	x	0,2,4,6,8,A,C or E	4	0100	EN
5	906.75	05	x	x	0,2,4,6,8,A,C or E	5		
6	907.50	06	x	x	0,2,4,6,8,A,C or E	6	1100	EN
7	908.25	07	x	x	0,2,4,6,8,A,C or E	7		
8	909.00	08	x	x	0,2,4,6,8,A,C or E	8	0010	EN
9	909.75	09	x	x	0,2,4,6,8,A,C or E	9		
10	910.50	0A	x	x	0,2,4,6,8,A,C or E	A	1010	EN
11	911.25	0B	x	x	0,2,4,6,8,A,C or E	B		
12	912.00	0C	x	x	0,2,4,6,8,A,C or E	C	0110	EN
13	912.75	0D	x	x	0,2,4,6,8,A,C or E	D		
14	913.50	0E	x	x	0,2,4,6,8,A,C or E	E	1110	EN
15	914.25	0F	x	x	0,2,4,6,8,A,C or E	F		
16	915.00	10	x	x	1,3,5,7,9,B,D or F	0	0001	EN
17	915.75	11	x	x	1,3,5,7,9,B,D or F	1		
18	916.50	12	x	x	1,3,5,7,9,B,D or F	2	1001	EN
19	917.25	13	x	x	1,3,5,7,9,B,D or F	3		
20	918.00	14	x	x	1,3,5,7,9,B,D or F	4	0101	EN
21	918.75	15	x	x	1,3,5,7,9,B,D or F	5		
22	919.50	16	x	x	1,3,5,7,9,B,D or F	6	1101	EN
23	920.25	17	x	x	1,3,5,7,9,B,D or F	7		
24	921.00	18	x	x	1,3,5,7,9,B,D or F	8	0011	EN
25	921.75	19	x	x	1,3,5,7,9,B,D or F	9		
26	922.50	1A	x	x	1,3,5,7,9,B,D or F	A	1011	EN
27	923.25	1B	x	x	1,3,5,7,9,B,D or F	B		
28	924.00	1C	x	x	1,3,5,7,9,B,D or F	C	0111	EN
29	924.75	1D	x	x	1,3,5,7,9,B,D or F	D		
30	925.50	1E	x	x	1,3,5,7,9,B,D or F	E	1111	EN
31	926.25	1F	x	x	1,3,5,7,9,B,D or F	F		

To revert to the default frequency, set all switches to the middle (tri-state) position and move the J4 Enable jumper to the DISABLE position if present.

Power must be reset upon any frequency setting changes.

SF900 Receiver

Electrical Characteristics

Sym	Parameter	Min	Typical	Max	Unit
	Operating Voltage Range	10	12	30	Volts
	Operating Current, Receive Mode		45	56	mA
	Operating Current, Transmit Mode		212	225	mA
	Input Resistance		4.7K		Ohms
	Output Relay Contact Ratings at 120 VAC			10	Amps
f	Frequency Range	902		928	MHz
P _{out}	Output Power		15		mW
Z _{out}	Antenna Input Impedance		50		Ohms
T _{op}	Operating Temperature	-20		+60	C

Ordering Information

Model No.	Product Description	Channels/ Buttons	Response Time
SF900C4-B-RX	Receiver	4	180 ms
SF900C4-J-RX	Receiver	4	58 ms
SF900C8-B-RX	Receiver	8	180 ms
SF900C8-J-RX	Receiver	8	58 ms
SF900C10-B-RX	Receiver	10	180 ms
SF900C10-J-RX	Receiver	10	58 ms
suffix -OPT14	NEMA 4X Enclosure 12-24 AC or DC Input		
Suffix -OPT14-PS	NEMA 4X Enclosure, 120/240VAC Input		

Related Optional Products

Model	Description	Volts	Current
610442-SAT	AC Power Adapter, 120VAC Input	12 V _{DC}	500 mA
610347	AC Power Adapter, 120VAC Input	24 V _{DC}	800 mA
610300	AC Power Transformer, 120VAC Input	24 V _{AC}	20 VA
269006	AC Power Line Contactor, SPST, 30A, 24VAC coil	240VAC	30A

Optional Antenna Bulkhead Extension Cables for SF900 Receivers

Model	Description	Length
600279-8	RPSMA Male to Female	8-Inches
600279-L100E-24	LMR-100 or Equiv.	24-Inches
600279-10F-L200	LMR-200 or Equiv.	10-Ft
600279-15F-L200	LMR-200 or Equiv.	15-Ft
600279-20F-L200	LMR-200 or Equiv.	20-Ft
600279-25F-L200	LMR-200 or Equiv.	25-Ft

Other lengths available

SFT900C Transmitter

Ordering Information

Model No.	Product Description	Channels/ Buttons	Range	Response Time
SFT900Cn-B	Handheld Transmitter, n-Buttons	n=1,2,3,4,6,8 or 10	¾-Mile	180 ms
SFT900Cn-	Handheld Transmitter, n-Buttons	n=1,2,3,4,6,8 or 10	1/3-Mile	58 ms
SFT900Cn-B-XANT	Handheld Transmitter, n-Buttons, External Antenna	n=1,2,3,4,6,8 or 10	2+ Miles	180 ms
SFT900Cn-J-XANT	Handheld Transmitter, n-Buttons, External Antenna	n=1,2,3,4,6,8 or 10	¾-Mile	58 ms
SFT900Cn-B-NTX	NEMA Wall Mount Transmitter, n-Buttons	n=1,2 or 3	¾-Mile	180 ms
SFT900Cn-B-NTX	NEMA Wall Mount Transmitter, n-Buttons	n=1,2 or 3	1/3-Mile	58 ms
SFT900Cn-B-NTX-XANT	NEMA Wall Mount Transmitter, External Antenna	n=1,2 or 3	2+ Miles	180 ms
SFT900Cn-J-NTX-XANT	NEMA Wall Mount Transmitter, External Antenna	n=1,2 or 3	¾-Mile	58 ms
Suffix -M to any Model No.	The addition of Internal Powerful Ceramic Magnets for Magnet Mounting			

SFT900 Specifications

Battery: CR123

Size: 4.625 x 3.25 x 1.0 Inches

Watertight Rating: IP-65

Low Battery Indication

When any button is pressed and held, the TX light will flash instead of being steady.

Custom Graphic Overlays

SFT900C handheld remote transmitters are available with customized graphic button overlay. Contact factory for details. Provide us the word(s) or graphic for each button and we will provide a proof for your review. All print is in black.

Example proof that we can provide:

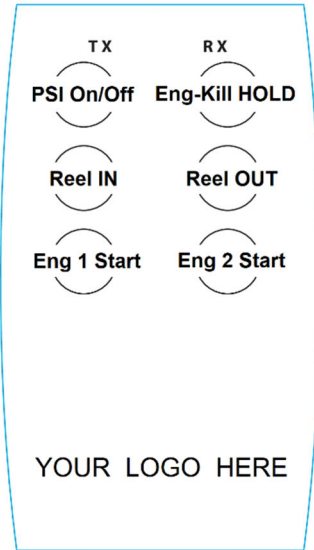

Receiver Package Information

Material: ABS

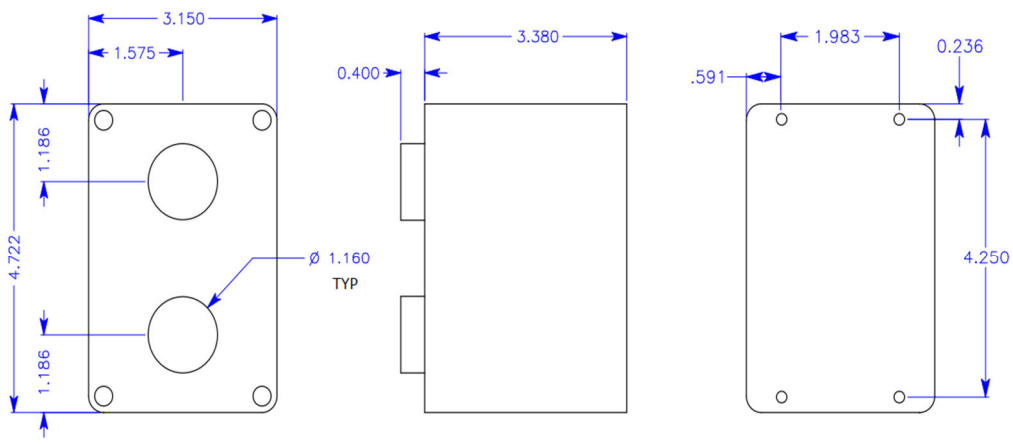
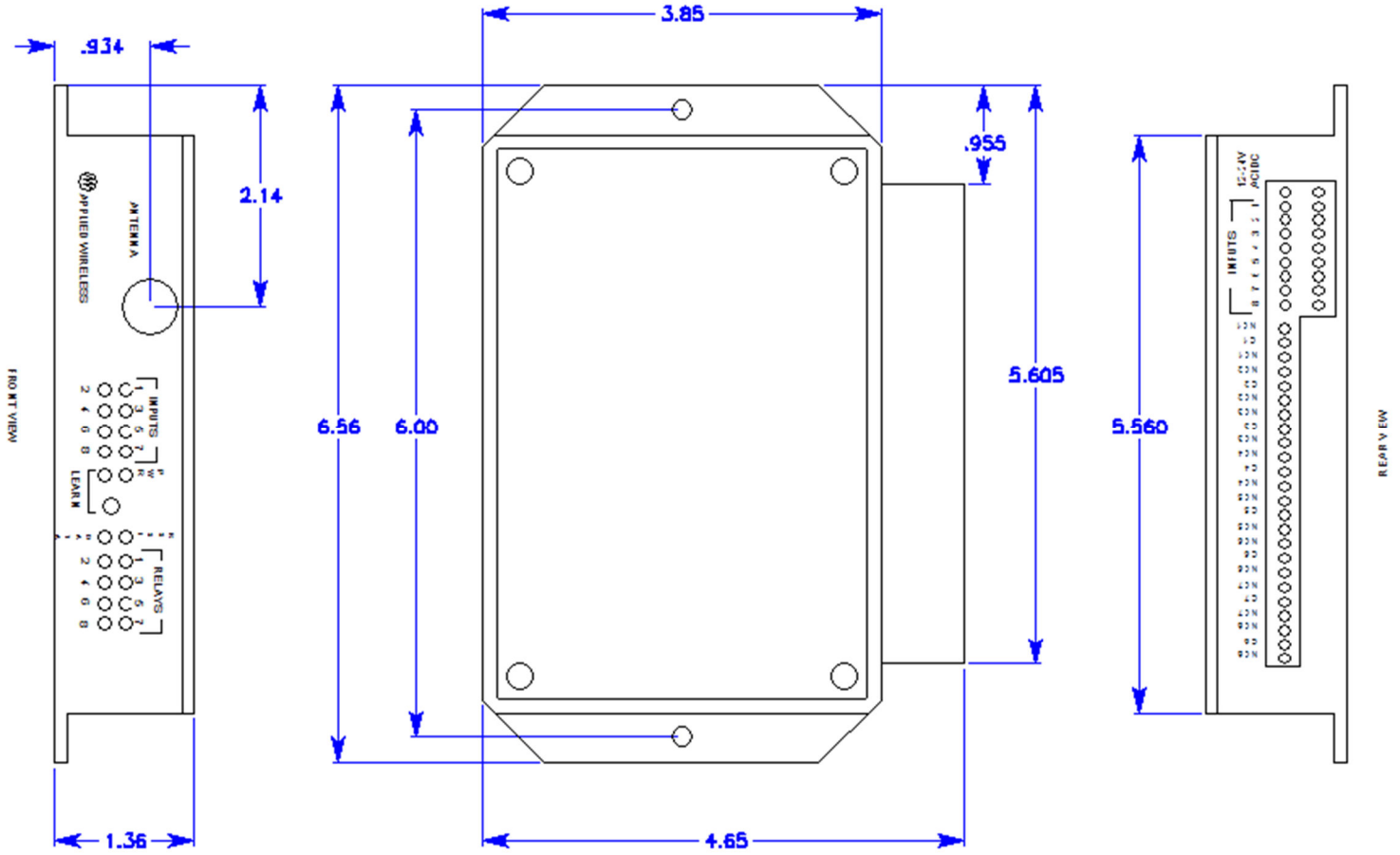

SFT900C2-B-NTX

Material: Polycarbonate
Rating: IP65

Removing the cover exposes recessed mounting holes for #6 or M3.5 screws for mounting the .135 inch thick back of the case to the mounting surface.

SF900 OPT14 Outdoor Package

Material: Polycarbonate

Rating: IP65

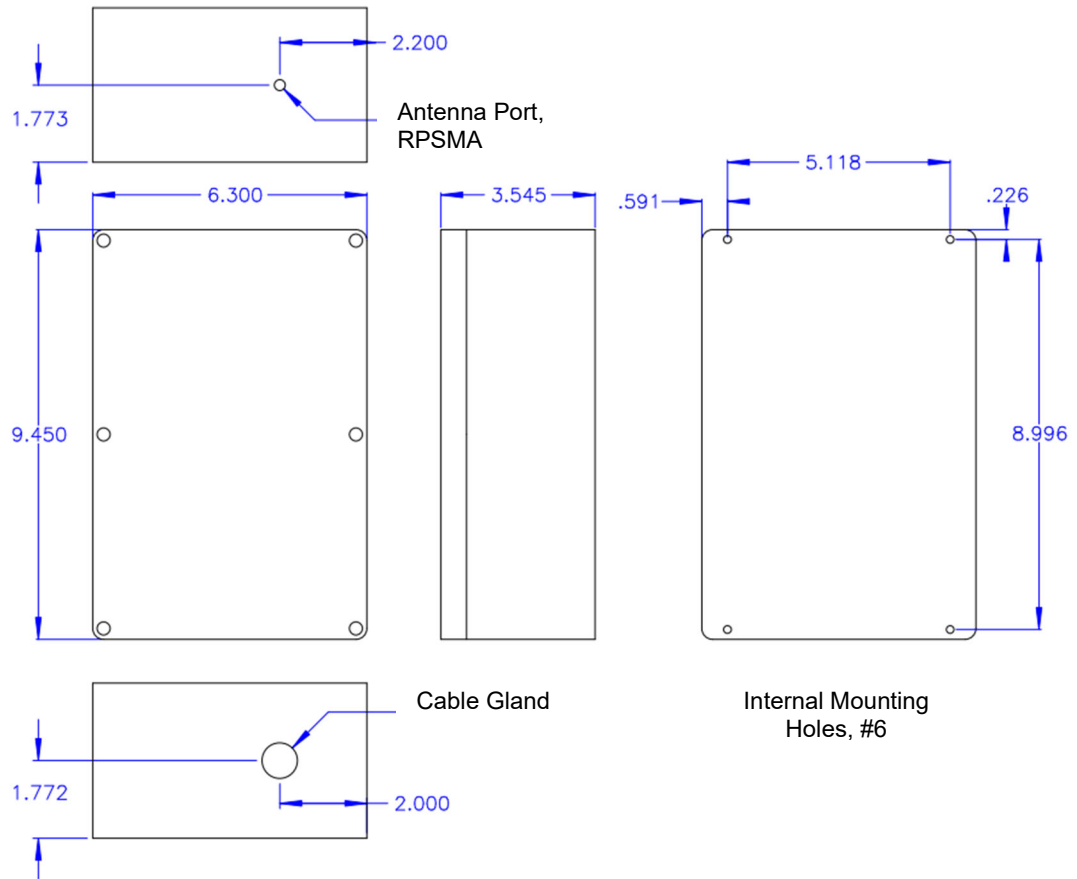

Application Drawing Forward/Reverse Motor Control

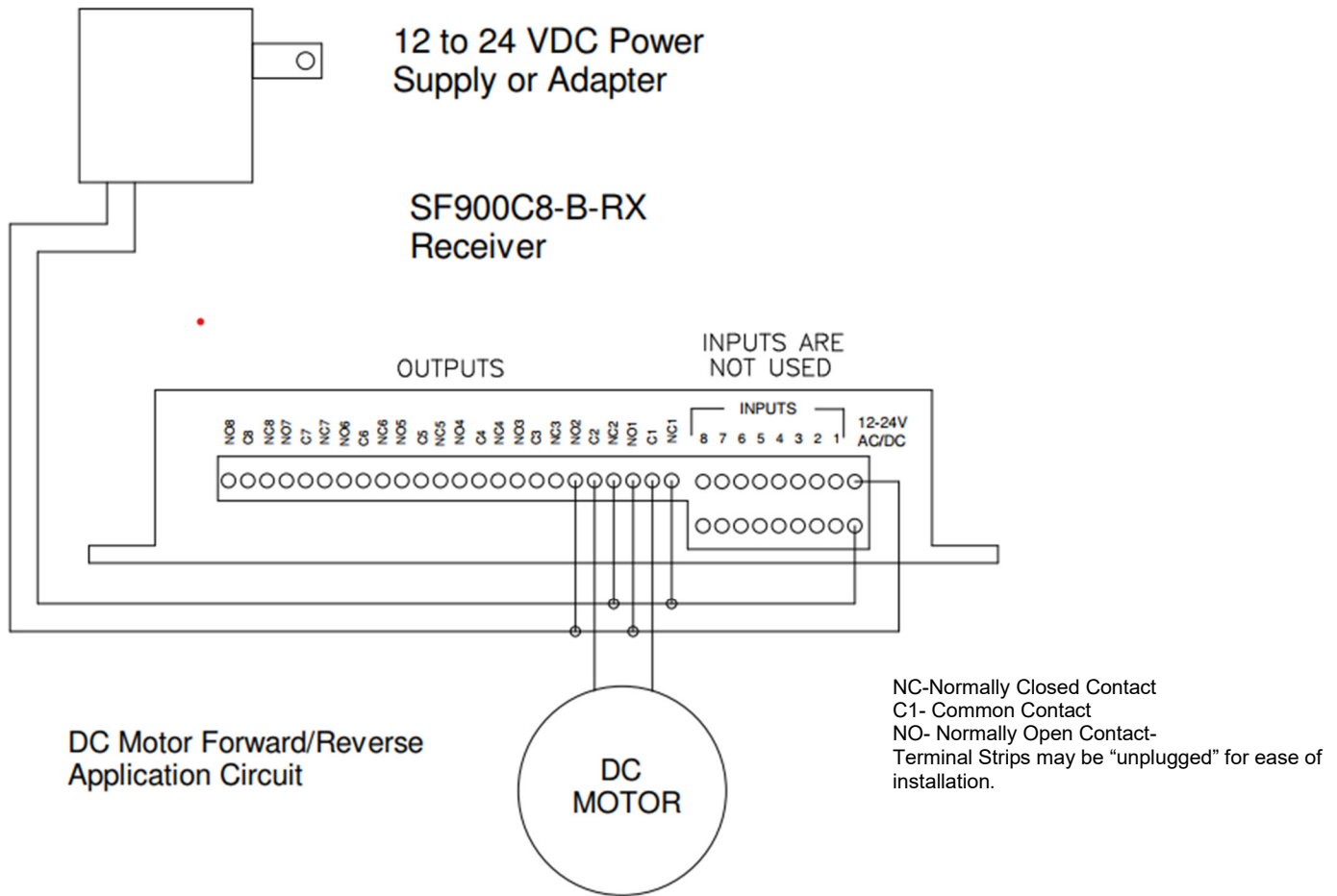

Troubleshooting Guide

Symptom	Possible Problem	Notes
Poor Range	Antenna or Antenna Placement	For omnidirectional operation, the antenna should be vertical and placed in a location clear of obstructions and as high as possible.
	RF Interference	Observe the DATA LED and try a different frequency if necessary.
Doesn't Work	Battery	Always check the battery. With a weak battery it is possible for the SFT900C transmit LED to work without transmissions occurring.
	Data Reception	Check that the DATA LED on the receiver is on bright when the transmitter is transmitting.
	ID Code Match	Transients can sometimes cause a unit to unlearn a code. Redo the Learning process.

ONE YEAR LIMITED WARRANTY (USA)

Products manufactured by APPLIED WIRELESS, INC. (AW) and sold to purchasers in the USA are warranted by AW according to the following terms and conditions. You should read this Warranty thoroughly.

● **WHAT IS COVERED, AND DURATION OF COVERAGE:**

AW warrants the product to be free from defects in materials and workmanship for one (1) year from the date of purchase by the original end user purchaser.

● **WHAT IS NOT COVERED:**

This warranty does not apply to the following:

1. Damage caused by accident, physical or electrical misuse or abuse, improper installation, failure to follow instructions contained in the User's Guide, any use contrary to the product's intended function, unauthorized service or alteration (i.e. service or alteration by anyone other than AW).
2. Damage occurring during shipment.
3. Damage caused by acts of God, including without limitation: earthquake, fire, flood, storms, or other acts of nature.
4. Damage or malfunction caused by the intrusion of moisture or other contamination within the product.
5. Batteries supplied by AW in or for the product.
6. Cosmetic deterioration of chassis, cases, or pushbuttons resulting from wear and tear typical of normal use.
7. Any cost or expense related to trouble-shooting to determine whether a malfunction is due to a defect in the product itself, in the installation, or any combination thereof.
8. Any cost or expense related to repairing or correcting the installation of an AW product.
9. Any cost or expense related to the removal or reinstallation of the product.
10. Any product whose serial number or date code is altered, defaced, obliterated, destroyed, or removed.

This warranty is extended to the original purchaser of the product(s) only, and is not transferable to any subsequent owner or owners of the product(s). AW reserves the right to make changes or improvements in its products without incurring any obligation to similarly alter products previously purchased.

● **EXCLUSION OF INCIDENTAL OR CONSEQUENTIAL DAMAGES:**

AW expressly disclaims liability for incidental and consequential damages caused (or allegedly caused) by the product. The term "incidental or consequential damages" refers (but is not limited) to:

1. Expenses of transporting the product to AW to obtain service.
2. Loss of use of the product.
3. Loss of the original purchaser's time.

● **LIMITATION OF IMPLIED WARRANTIES:**

This warranty limits AW's liability to the repair or replacement of the product. AW makes no express warranty of merchantability or fitness for use. Any implied warranties, including fitness for use and merchantability, are limited in duration to the period of the one (1) year express limited warranty set forth herein. The remedies provided under this warranty are exclusive and in lieu of all others. AW neither assumes nor authorizes any person or organization to make any warranties or assume any liability in connection with the sale, installation, or use of this product.

Some states do not allow limitations on how long an implied warranty lasts, and some states do not allow the exclusion or limitation of liability for incidental or consequential damages so the limitations or exclusions stated herein may not apply to you. This warranty gives you specific legal rights and you may have other rights which vary from state to state.

● **HOW TO OBTAIN WARRANTY SERVICE:**

If a product covered by this warranty and sold in the USA by AW proves to be defective during the warranty period AW will, at its sole option, repair it or replace it with a comparable new or reconditioned product without charge for parts and labor, when said product is returned in compliance with the following requirements:

1. You must first contact AW at the following address/phone for assistance:

**APPLIED WIRELESS, INC.
1250 Avenida Acaso, Suite F
Camarillo, CA 93012
Phone: (805) 383-9600**

If you are instructed to return your product directly to the factory, a Return Merchandise Authorization number (RMA) will be issued to you.

2. You must package the product carefully and ship it insured and prepaid. The RMA number must be clearly indicated on the outside of the shipping container. *Any product returned without an RMA number will be refused delivery.*
3. In order for AW to perform service under warranty, you must include the following:
 - (a) Your name, return shipping address (not a PO Box), and daytime telephone number.
 - (b) Proof of purchase showing the date of purchase.
 - (c) A detailed description of the defect or problem.

Upon completion of service, AW will ship the product to the specified return shipping address. The method of shipping shall be at AW's sole discretion. The cost of return shipping (within USA) shall be borne by AW.



Applied Wireless products are designed and manufactured with pride in the United States of America

© Copyright 2017 by Applied Wireless, Inc. All rights reserved.
Specifications subject to change without notice.

APPLIED WIRELESS, INC.
1250 Avenida Acaso, Ste. F Camarillo, CA 93012
Phone: 805-383-9600 Fax: 805-383-9001
Email: sales@appliedwireless.com
www.appliedwireless.com