

## 900 MHz Wireless Switch Follower/Remote Control Receiver (with On-Board 10-Amp Relays)

The SF900C Series Remote Control/Switch Followers are a two-way system designed to provide a quick and cost effective solution for a variety of wireless switching applications. Each unit has multiple (4 or 8) inputs connected to a transmitter and 4/8 outputs connected to a receiver. Designed to work in pairs, the output relay at the *receive* end of one unit will “follow” the input at the *transmit* end of the paired unit.

The inputs are opto-isolated and may be operated by an applied voltage that can be supplied by a power source from 5 to 24 Volts AC or DC through a switch contact, relay, sensor, PLC output, etc.

Alternatively, instead of automatic “switch following” operation, the SF900C can operate as a 4/8-channel wireless relay using a SFT900C handheld remote control. The default mode is Momentary but with optional custom software, Latched and Toggle modes are available for special applications. When a button is pushed on the SFT900C, an RX LED and optional Beep will indicate that the proper relay was triggered after receiving a verified acknowledgment reply from the SF900C. In this mode, multiple transmitters can be used with one receiver as well as one transmitter can transmit to multiple receivers.



These products utilize spread spectrum technology and are immune to interference and multipath fading. All inputs and outputs are independently isolated from each other and from the power supply ground. The antenna, however, is connected to the internal ground and, if AC powered, **the antenna must be isolated from the power input ground.**

### Features

- 4-Inputs/4 each-10A Relay Outputs or
- 8-Inputs/8 each 10A Relay Outputs or
- 10 each 10A Relay Outputs
- Long Range: 1 to 5-miles
- Two-Way Operation
- Spread Spectrum Technology
- Isolated Inputs and Outputs
- 12-36 Volt DC or AC Operation
- Handheld Remotes Available
- Optional NEMA 4X Wall Mount Remote Available
- Antenna Included
- FCC Certified
- Made in USA

### Typical Applications

- Pump Control
- Motor Control
- Solenoid Control
- Lighting Control
- Access Control
- PLC Activation
- HVAC Control

### Ordering Information

Model No.	Product Description	Channels	Range	Response Time
SF900C4-B	Switch Follower Transceiver	4	2.5-Miles	180ms
SF900C4-J	Switch Follower Transceiver	4	½-Mile	58ms
SF900C8-B	Switch Follower Transceiver	8	2.5-Miles	180ms
SF900C8-J	Switch Follower Transceiver	8	½-Mile	58ms
SF900C10-B	Receiver Only	10	2.5-Miles	180 ms
SF900C10-J	Receiver Only	10	½-Mile	58 ms
SFT900Cn	Handheld Transmitter, n-Buttons	n=1,2,3,4,6,8 or 10		
suffix -OPT14	NEMA 4X Enclosure Package			

Specifications subject to change without notice or obligation.

## Electrical Characteristics

Sym	Parameter	Min	Typ	Max	Unit
	Operating Voltage Range	10	12	36	Volts
	Operating Current, Receive Mode		45	56	mA
	Operating Current, Transmit Mode		212	225	mA
	Input Resistance		4.7K		Ohms
	Signal Input Voltage	5		24	Volts AC or DC
	Output Relay Contact Ratings at 28VDC			10	Amps
f	Frequency Range	902		928	MHz
Z <sub>out</sub>	Antenna Input Impedance		50		Ohms
T <sub>op</sub>	Operating Temperature	-20		+60	C

## Package Dimensions

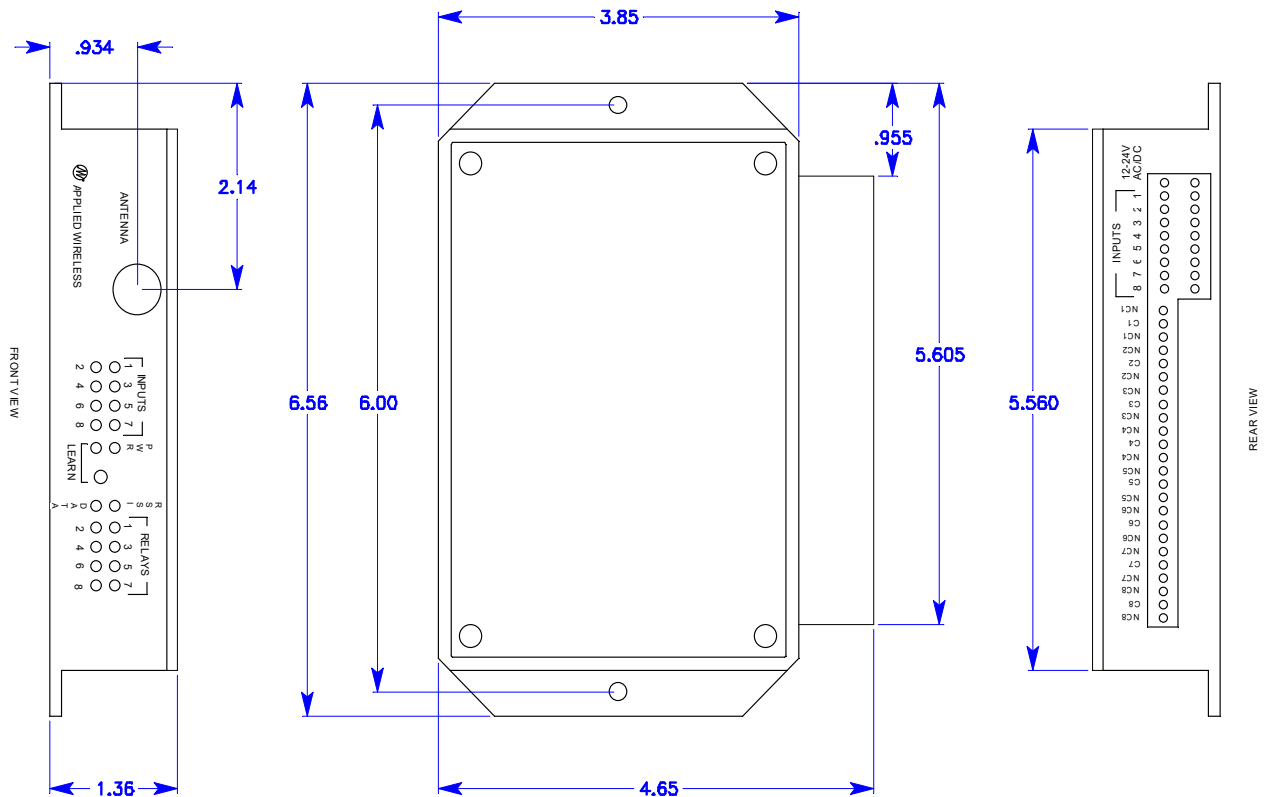

## RELATED PRODUCTS

600279-8	RPSMA ANTENNA BULKHEAD EXTENSION CABLE, 8.5"
600279-L200E-72	RPSMA ANTENNA BULKHEAD EXTENSION CABLE, 6 FT
OPTION 14	NEMA ENCLOSURE WITH CABLE GLANDS

Specifications subject to change without notice or obligation.

[www.appliedwireless.com](http://www.appliedwireless.com) • Tel: (805) 383-9600 • Fax (805) 383-9001

Revised 8/10/2021

## LEARN PROCEDURE

**STANDARD TWO WAY APPLICATION:** To pair two SF900C units, place both units in the learn mode by pushing their respective learn buttons. The learn lights will flash. Let's call one the Base unit and the other the Remote unit. The second push of the learn button on the Remote unit will trigger the learning process. Once completed, the learn lights will turn Off. The Remote unit will have learned and adopted the code and frequency of the Base unit. The Base unit is defined as the unit that has not adopted an alternate code. The distinction is important for the next example.

**RECEIVER/TRANSMITTER APPLICATION:** To pair a SF900C to be used as a receiver with a SFT900C handheld transmitter. More than 1 SFT900C handheld remote transmitter may also be learned to a single SF900C receiver:

1. The circuit board of the SFT900C will have to be accessed. Remove the 4 screws from the back cover and remove the cover.
2. Place both units in the learn mode by pushing the respective learn buttons, one for the SFT900C handheld, and one for the SF900C receiver. The learn lights will flash.
3. Then press the LEARN button on the SFT900C handheld transmitter again and the pairing will take place. Replace the cover and 4 screws, being careful not to pinch the gasket.

The SFT900C handheld remote will have learned the code and frequency of the SF900C receiver. Other transmitters can be added one at a time by repeating the learn process. All of the transmitters will have learned the receiver's address code and frequency.

More SF900C receivers can be added to the above system one at a time by using the same SF900C as the Base unit. However, the covers will have to be removed from the additional SF900C receivers and the ACK jumper will have to be moved to the NO ACK position to disable acknowledgements. When a signal is received from a transmitter, only one receiver, logically the Base unit, must reply with an acknowledgment to avoid collisions.



*SFT900C LEARN  
Button Location 1*



*SF900C LEARN Button & LEARN Light*

## CHANGING THE FREQUENCY:

The least significant 5 bits of the address of the Base unit is used to determine the frequency of operation, one of 32 possible. Therefore, there is a 1 in 32 chance that any two units will be operating on the same frequency. The label on the units will have the 4 hex digit code as well as a 2 digit hex frequency. If two or more Base units are to be operating in the same area and they have the frequency, the Base units can be set to different frequencies.

For those units that have a 6 position tri-state dip switch at S1, switches 1 - 5 set the frequency by moving the switches to the up or down position and switch 6 is an enable switch for the alternate frequency selection if set to the down position. The center tri-state position for all of the switches disables the alternate frequency switch function.

An alternate is a 4 position dip switch covering switch positions 2 - 5 and an enable jumper in place of switch 6 allowing for 16 possible frequencies. To enable the alternate frequency selection, Jumper J4 must be moved to the two pins closest to the "EN" position and each of the dip switches must be moved up or down. To disable the alternate frequency selection, the enable jumper must be moved to the two pins farthest from the the EN location and the dip switches must be moved to the center tri-state position. See the Frequency Select Switch Table. (1 is UP and 0 is DOWN).

Specifications subject to change without notice or obligation.

NOTE: Whenever the frequency select switch, S1, is changed on the Base unit, the power has to be turned Off and back On again for the frequency change to take effect. Then, the Learn Procedure will have to be repeated for all of the Remote units associated with the Base unit that has a new frequency setting.

## FREQUENCY SELECT SWITCH TABLE

CHANNEL <u>Decimal</u>	CHANNEL <u>HEX</u>	6 Position Switch <u>BINARY, lsb first</u>	4 Position Switch <u>BINARY, lsb first</u>
0	00	000000	0000 EN
1	01	100000	
2	02	010000	1000 EN
3	03	110000	
4	04	001000	0100 EN
5	05	101000	
6	06	011000	1100 EN
7	07	111000	
8	08	000100	0010 EN
9	09	100100	
10	0A	010100	1010 EN
11	0B	110100	
12	0C	001100	0110 EN
13	0D	101100	
14	0E	011100	1110 EN
15	0F	111100	
16	10	000010	0001 EN
17	11	100010	
18	12	010010	1001 EN
19	13	110010	
20	14	001010	0101 EN
21	15	101010	
22	16	011010	1101 EN
23	17	111010	
24	18	000110	0011 EN
25	19	100110	
26	1A	010110	1011 EN
27	1B	110110	
28	1C	001110	0111 EN
29	1D	101110	
30	1E	011110	1111 EN
31	1F	111110	

Specifications subject to change without notice or obligation.

# SF C-Series

## Application Circuit – Standard

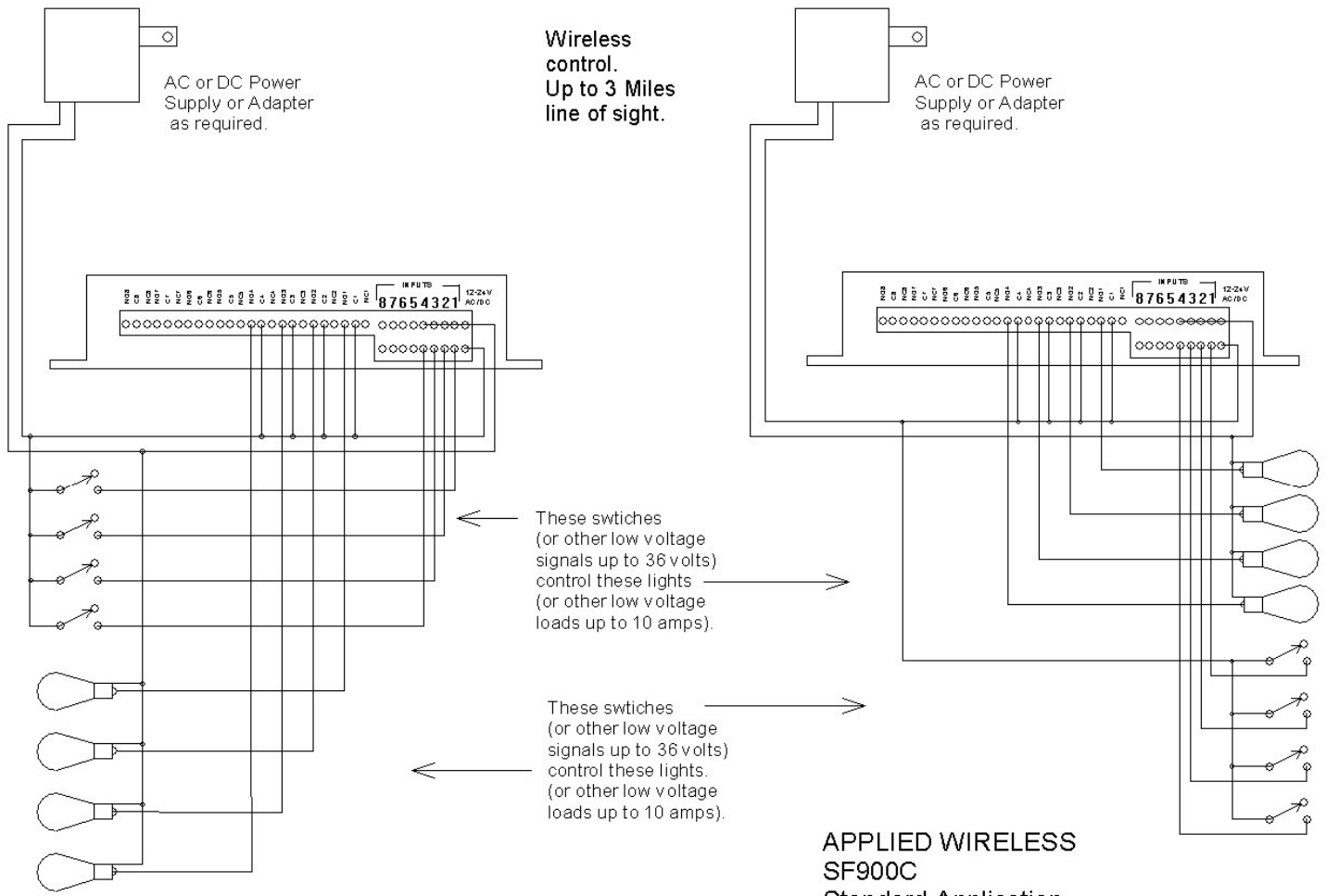

**APPLIED WIRELESS SF900C**  
 Standard Application  
 4 of 8 circuits shown

Specifications subject to change without notice or obligation.

**www.appliedwireless.com • Tel: (805) 383-9600 • Fax (805) 383-9001**

Revised 8/10/2021

# SF C-Series

Application Circuit - Loopback Mode

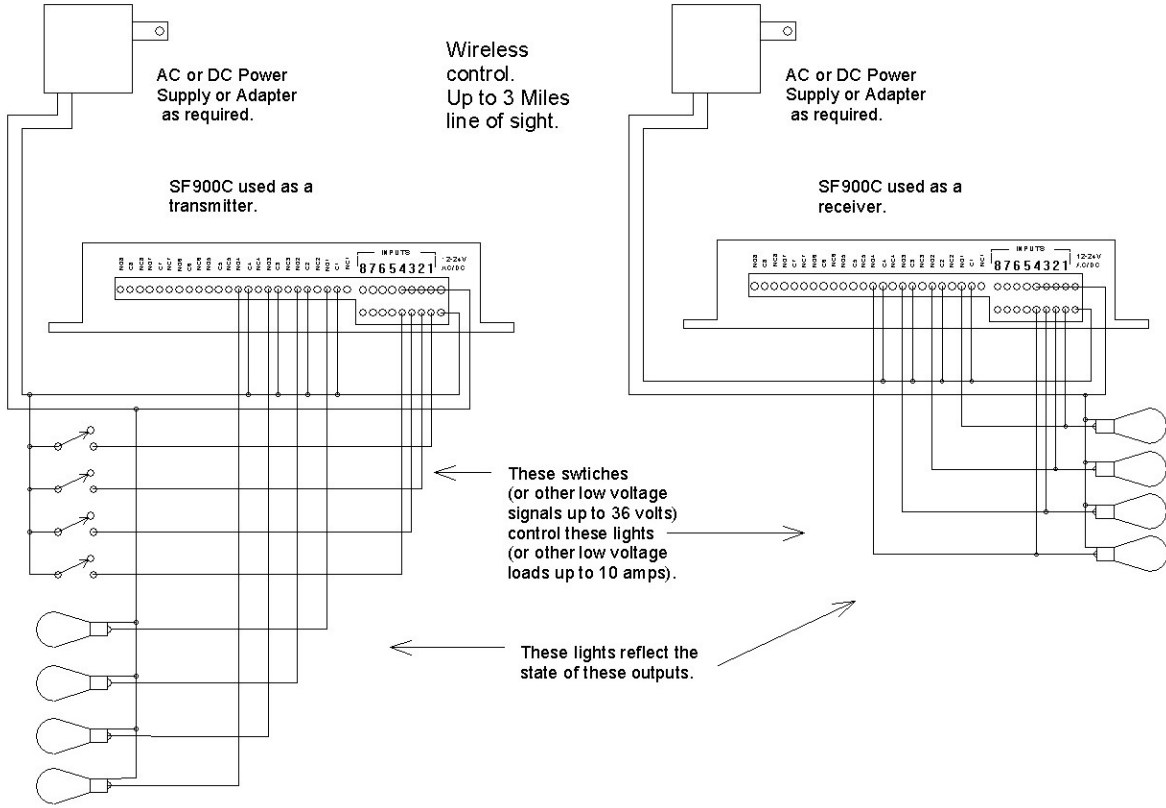

Application Circuit - Thermostat to HVAC

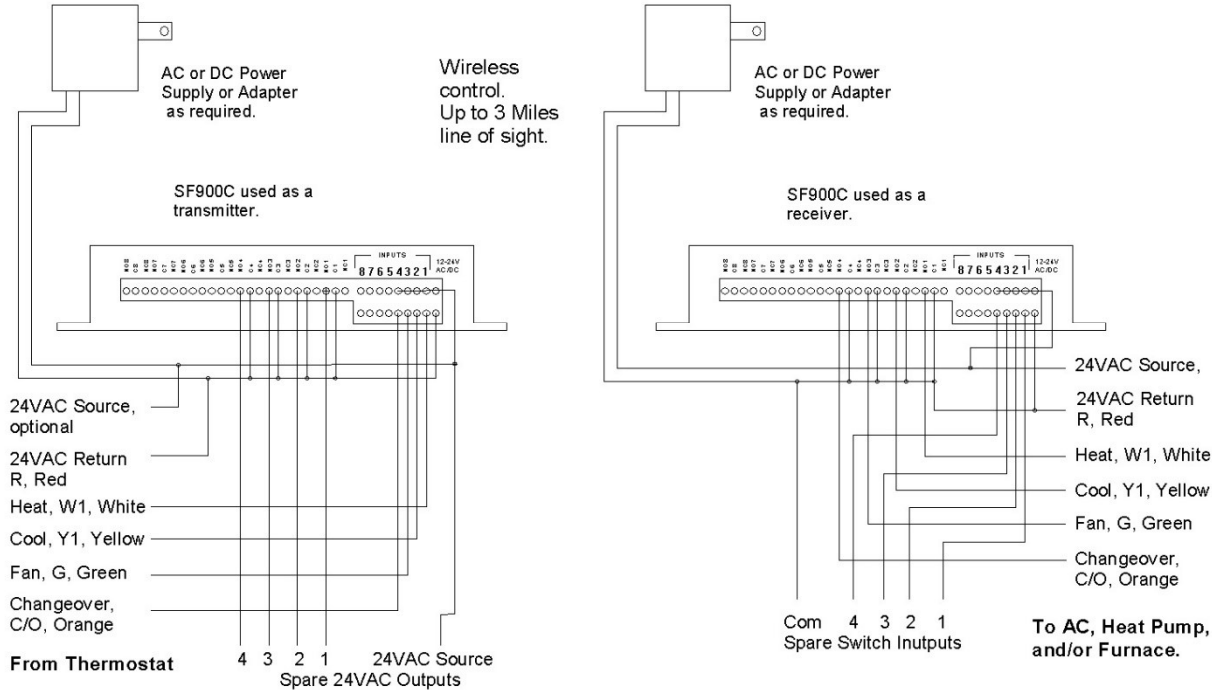

Specifications subject to change without notice or obligation.

[www.appliedwireless.com](http://www.appliedwireless.com) • Tel: (805) 383-9600 • Fax (805) 383-9001

Revised 8/10/2021

**FCC ID: QY4-618**

“This device complies with Part 15 of the FCC Rules. Operation is subject to the following two conditions: (1) this device may not cause harmful interference, and (2) this device must accept any interference received, including interference that may cause undesired operation.”

**INSTRUCTION TO THE USER**

Note: This equipment has been tested and found to comply with the limits for a Class B digital device, pursuant to part 15 of the FCC Rules. These limits are designed to provide reasonable protection against harmful interference in a residential installation. This equipment generates, uses and can radiate radio frequency energy and, if not installed and used in accordance with the instructions, may cause harmful interference to radio communications. However, there is no guarantee that interference will not occur in a particular installation. If this equipment does cause harmful interference to radio or television reception, which can be determined by turning the equipment off and on, the user is encouraged to try to correct the interference by one or more of the following measures:

- Connect the equipment into an outlet on a circuit different from that to which the receiver is connected.
- Consult an experienced radio/TV technician for help.

Changes or modifications not expressly approved by Applied Wireless could void the user's authority to operate the equipment.